

X=370µm Y=370µm

Features

- ◆ RF Frequency: dc to 7 GHz
- ◆ Gain: 14 dB typ.
- ◆ P1dB: 16 dBm
- ◆ IP3: 30 dBm
- ◆ Noise figure: 5.1 dB
- ◆ GaAs HBT technology
- ◆ Die Size: < 0.14 sq. mm

Performance Characteristics
(Ta = 25°C, Ic = 60mA)

Specification	Min	Typ	Max	Unit
Gain at 1 GHz	11	14		dB
1dB bandwidth		5		GHz
3 dB bandwidth		7.0		GHz
P1dB at 1 GHz		16		dBm
IP3 at 1 GHz		30		dBm
NF at 1 GHz		5.1		dB
Input Return Loss at 1 GHz		12		dB
Output Return Loss at 1 GHz		14		dB
Supply voltage	4.7		5.7	V
Supply current		60		mA

Applications

- ◆ Driver Amplifier
- ◆ IF Amplifier
- ◆ Cellular/PCS
- ◆ Wireless LANs

Product Description

The AHB108 monolithic HBT Darlington amplifier designed for use as a general purpose 50-ohm gain block for terrestrial use. External dc blocking capacitors determine low-frequency response, and an external bias resistor gives bias voltage flexibility.

Absolute Maximum Ratings (Ta = 25°C)

Parameter	Min	Max	Unit
Supply Current		65	mA
Supply Voltage *		6	V
Input drive level		7	dBm
Operating temperature		85	deg. C
Assy. Temperature (60 seconds)		300	deg. C

* VCC specified at bonding pad only

Note: The data contained in this document is for information only. Northrop Grumman reserves the right to change without notice the specifications, designs, prices or conditions of sale, as they apply to this product. The product represented by this datasheet is subject to U.S. Export Law as contained in ITAR or the EAR regulations.



Linear Gain Versus Frequency

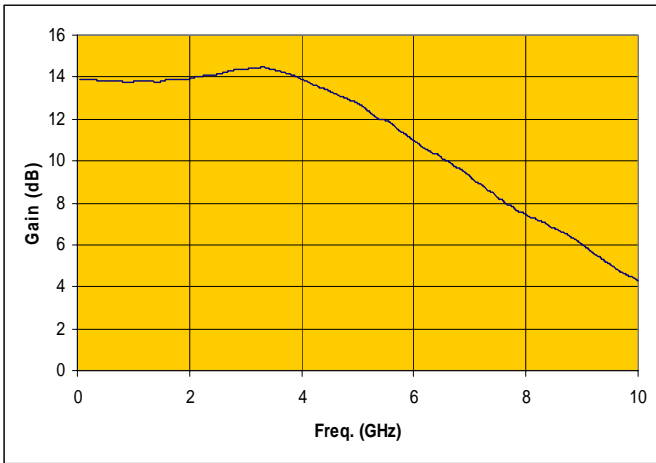

Noise Figure Versus Frequency

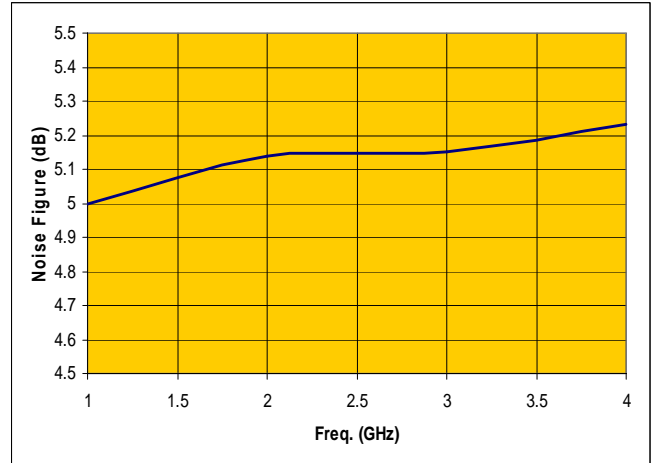

IP3 Versus Frequency

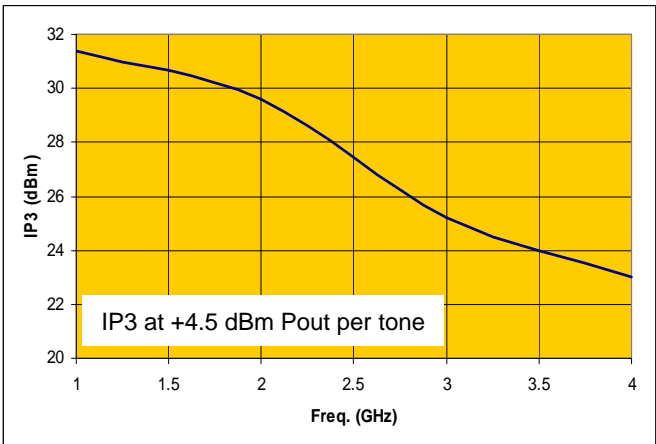

P1dB Versus Frequency

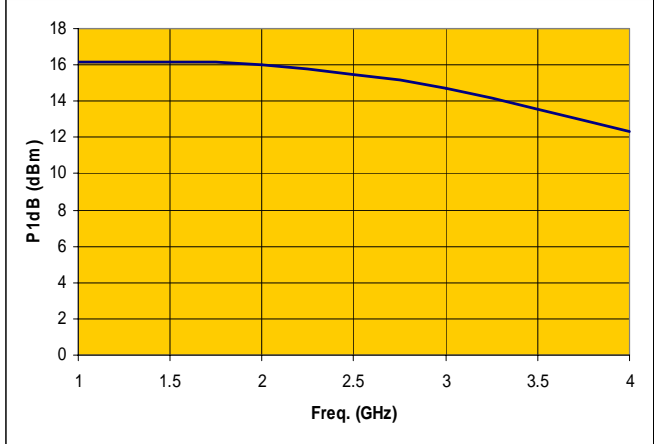

Input Return Loss Versus Frequency

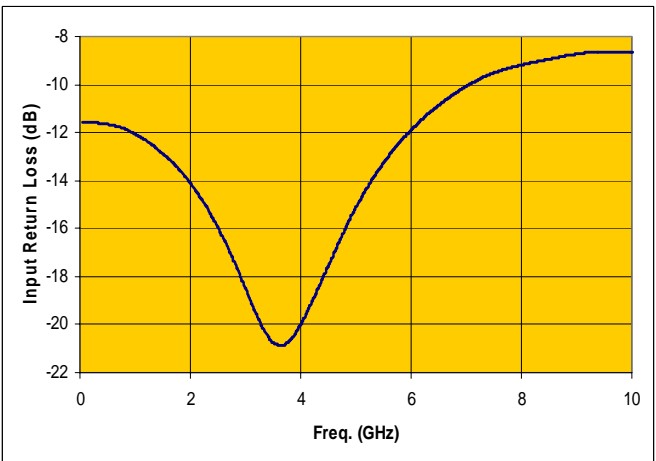

Output Return Loss Versus Frequency

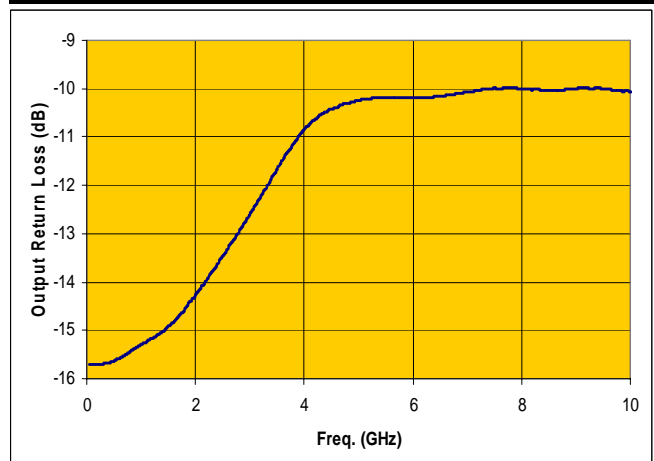

Note: The data contained in this document is for information only. Northrop Grumman reserves the right to change without notice the specifications, designs, prices or conditions of sale, as they apply to this product. The product represented by this datasheet is subject to U.S. Export Law as contained in ITAR or the EAR regulations.



Product Datasheet **Discontinued 2/16/2006**

Revision: February 2006

Typical Bias Configuration

Simplified Schematic of MMIC

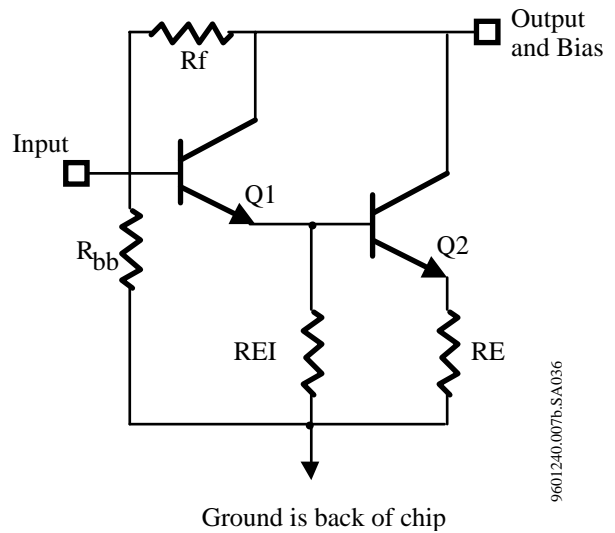
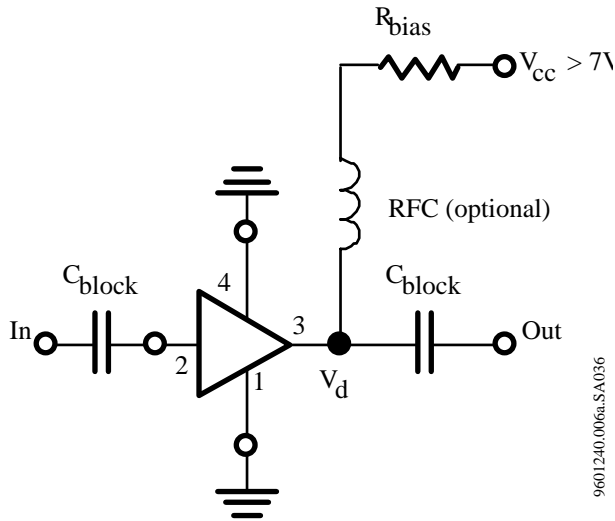

Note

Failure to use ≥ 1.5 V drop across R_{bias} may result in excessive device current at hot temperature and/or in overdrive conditions.

Typical Bias Configuration

Die Size and Bond Pad Locations

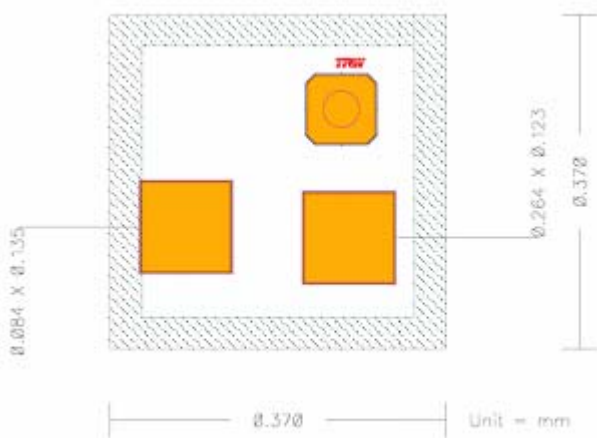

Suggested Bonding Arrangement

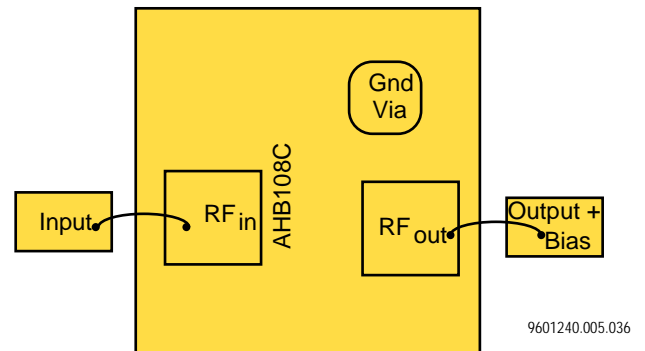

Recommended Assembly Notes

- Chip input and output dc coupled.
- Backside of chip is ground.
- Third Pad is Ground via; do not bond.

Note: The data contained in this document is for information only. Northrop Grumman reserves the right to change without notice the specifications, designs, prices or conditions of sale, as they apply to this product. The product represented by this datasheet is subject to U.S. Export Law as contained in ITAR or the EAR regulations.