

X=5550µm Y=2500µm

**Product Features**

- ◆ RF Frequency: 37 to 40 GHz
- ◆ Linear gain: 12 dB, typical
- ◆ P1dB: 28 dBm, typical
- ◆ IP3: 37 dBm, typical
- ◆ Unconditionally stable
- ◆ Excellent input and output VSWR
- ◆ DC Power: 5.0 Vdc at 960 mA

**Performance Characteristics (Ta = 25°C)**

Specification	Min	Typ	Max	Unit
Frequency	37		40	GHz
Linear Gain	10	12		dB
P1dB	26.5	28		dBm
IP3		37		dBm
(@ 18 dBm/tone)				
Input Return Loss	15	20		dB
Output Return Loss	12	15		dB
Vd1, Vd1A		5		V
Vd2, Vd2A				
Vg1, Vg1A		-0.4		V
Vg2, Vg2A				
Id1		160		mA
Id1A		160		mA
Id2		320		mA
Id2A		320		mA

**Applications**

- ◆ Point-to-point Digital Radios
- ◆ Point-to-Multipoint Digital Radios

**Product Description**

The APH309C monolithic HEMT amplifier, a broadband, two-stage power device, is designed for use in commercial digital radios and wireless LANs. The balanced design provides unconditional stability as well as excellent input and output VSWR. To ensure rugged and reliable operation, HEMT devices are fully passivated. Both bond pad and backside metallization are Ti/Au, which is compatible with conventional die attach, thermocompression, and thermosonic wire bonding assembly techniques.

**Absolute Maximum Ratings (Ta = 25°C)**

Parameter	Min	Max	Unit
Vd1, Vd1A		6	V
Vd2, Vd2A			
Id1		260	mA
Id1A		260	mA
Id2		520	mA
Id2A		520	mA
Vg1, Vg1A	-1	+0.3	V
Vg2, Vg2A			
Input drive level		17	dBm
Assy. Temperature (60 seconds)		300	deg. C

Note: The data contained in this document is for information only. Northrop Grumman reserves the right to change without notice the specifications, designs, prices or conditions of sale, as they apply to this product. The product represented by this datasheet is subject to U.S. Export Law as contained in ITAR or the EAR regulations.



Product Datasheet **Discontinued 06/16/2006**

Revision: June 2006

Measured Performance Characteristics (Typical Performance at 25°C)  
 Vd = 5 V, Id = 1000 mA

Freq GHz	S11 Mag	S11 Ang	S21 Mag	S21 Ang	S12 Mag	S12 Ang	S22 Mag	S22 Ang
35.0	0.10	33.64	3.18	102.95	0.02	106.74	0.10	121.89
35.5	0.09	32.93	3.53	79.50	0.01	65.72	0.04	116.59
36.0	0.08	30.90	3.87	55.18	0.01	120.25	0.06	114.98
36.5	0.10	34.41	4.27	29.93	0.01	27.95	0.08	97.95
37.0	0.12	32.40	4.52	2.36	0.01	63.98	0.06	117.65
37.5	0.13	23.38	4.71	-25.13	0.01	14.87	0.08	94.34
38.0	0.13	5.22	4.80	-53.17	0.02	-30.22	0.10	109.36
38.5	0.09	-17.96	4.82	-81.74	0.02	-43.62	0.13	84.52
39.0	0.04	-34.89	4.72	-110.42	0.01	-73.19	0.12	64.54
39.5	0.01	120.10	4.61	-138.67	0.01	-92.08	0.14	53.55
40.0	0.04	95.94	4.49	-165.47	0.01	-118.49	0.15	40.51
40.5	0.07	71.77	4.38	-192.27	0.02	-144.90	0.17	27.46

Note: The data contained in this document is for information only. Northrop Grumman reserves the right to change without notice the specifications, designs, prices or conditions of sale, as they apply to this product. The product represented by this datasheet is subject to U.S. Export Law as contained in ITAR or the EAR regulations.



Product Datasheet **Discontinued 06/16/2006**

Revision: June 2006

Measured Performance Characteristics (Typical Performance at 25°C)  
Vd = 5 V, Id = 1000 mA

**Pulsed Gain Versus Frequency**

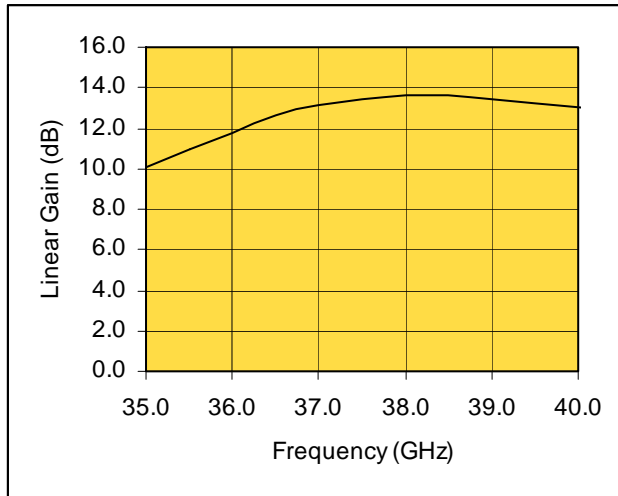

**P1dB and IP3 Versus Frequency**

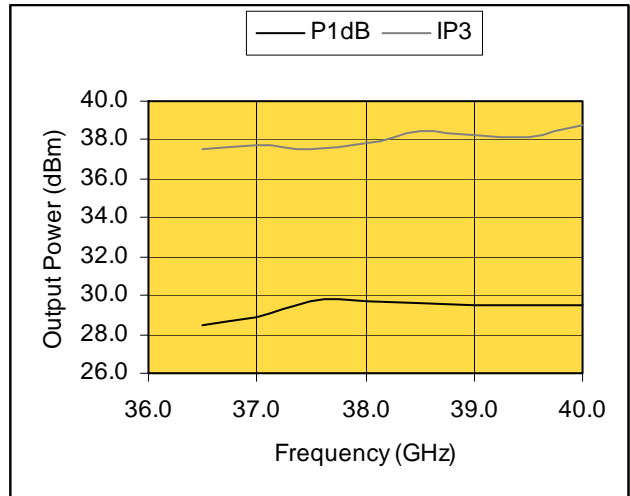

**Input Return Loss Versus Frequency**

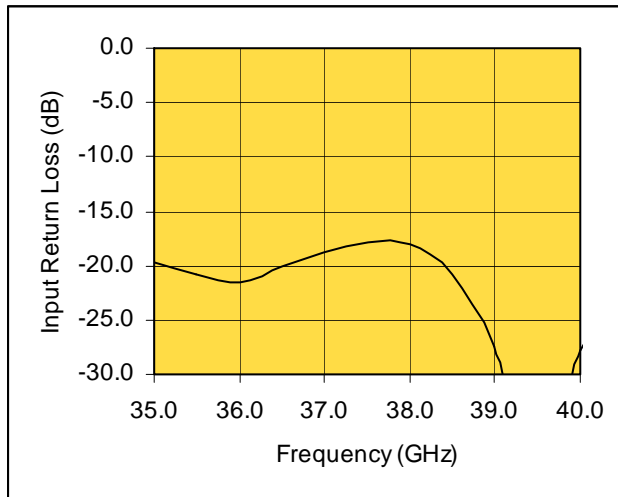

**Output Return Loss Versus Frequency**

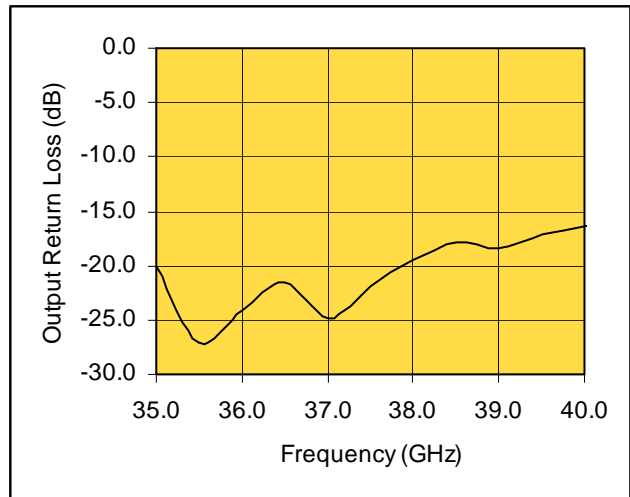

Note: The data contained in this document is for information only. Northrop Grumman reserves the right to change without notice the specifications, designs, prices or conditions of sale, as they apply to this product. The product represented by this datasheet is subject to U.S. Export Law as contained in ITAR or the EAR regulations.



Product Datasheet **Discontinued 06/16/2006**

Revision: June 2006

Die Size and Bond Pad Locations

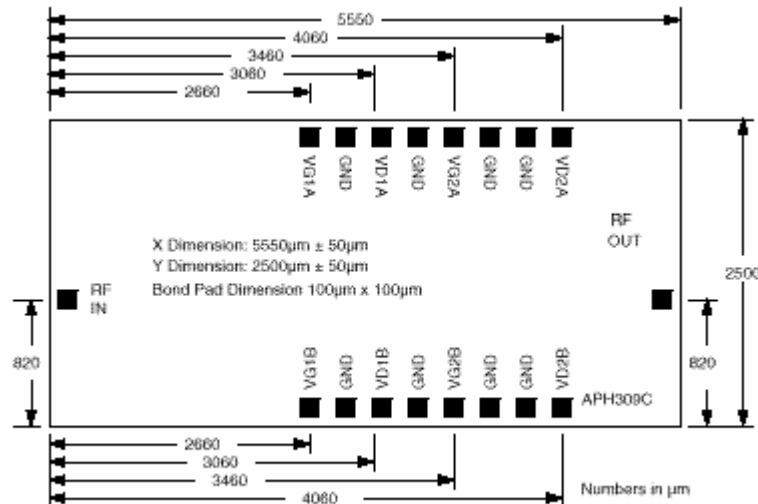

Suggested Bonding Arrangement

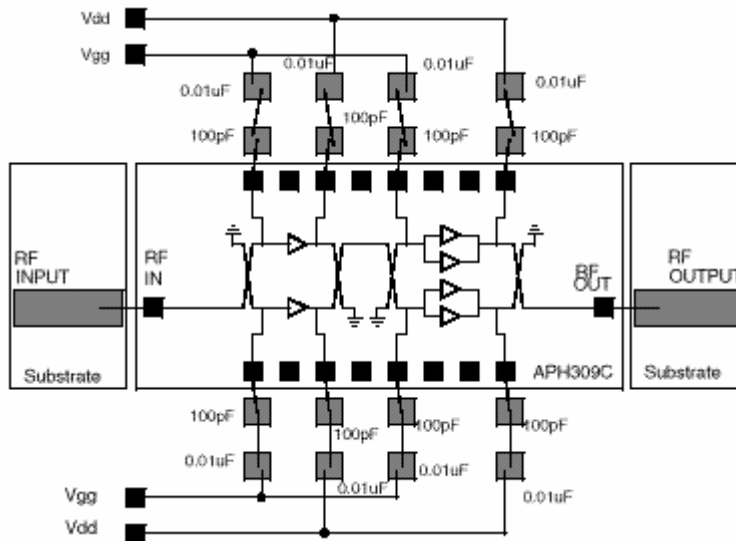

Note: 10 Ohm series resistor can be added on the gate lines between the 100pF and the .01µF caps for additional bypassing.

Recommended Assembly Notes

1. Bypass caps should be 100 pF ceramic (single-layer) placed no further than 30 mils from the amplifier.
2. Best performance obtained from use of <10 mil (long) by 3 by 0.5 mil ribbons on input and output.

Note: The data contained in this document is for information only. Northrop Grumman reserves the right to change without notice the specifications, designs, prices or conditions of sale, as they apply to this product. The product represented by this datasheet is subject to U.S. Export Law as contained in ITAR or the EAR regulations.