

X=1960μm Y=1100μm

Product Features

- ◆ RF Frequency: 27 to 30 GHz
- ◆ Linear gain: 20 dB, typical
- ◆ P1dB: 24-26 dBm, typical
- ◆ IP3: 33 dBm, typical
- ◆ Unconditionally stable
- ◆ DC Power: 5.0 Vdc at 426 mA

Performance Characteristics (Ta = 25°C)

Specification	Min	Typ	Max	Unit
Frequency	27		30	GHz
Linear Gain	15	20		dB
P1dB	22	24		dBm
IP3		33		dBm
Input Return Loss		5		dB
Output Return Loss		5		dB
Frequency	27		28	GHz
Linear Gain	18	20		dB
P1dB	23	24		dBm
Frequency	28.1		30	GHz
Linear Gain	20	22		dB
P1dB	24	26		dBm
Vd1, Vd2		5		V
Vg1, Vg2		-0.5		V
Id1		126		mA
Id2		300		mA

Applications

- ◆ Point-to-Point Digital Radios
- ◆ Point-to-Multipoint Digital Radios
- ◆ VSAT

Product Description

The APH399 monolithic HEMT amplifier, a broadband, two-stage power device, is designed for use in commercial digital radios and wireless LANs. To ensure rugged and reliable operation, HEMT devices are fully passivated. Both bond pad and backside metallization are Ti/Au, which is compatible with conventional die attach, thermocompression, and thermosonic wire bonding assembly techniques.

Absolute Maximum Ratings (Ta = 25°C)

Parameter	Min	Max	Unit
Vd1, Vd2		6	V
Id1		150	mA
Id2		360	mA
Vg1, Vg2	-1	+0.3	V
Input drive level		10	dBm
Assy. Temperature (60 seconds)		300	deg. C

Note: The data contained in this document is for information only. Northrop Grumman reserves the right to change without notice the specifications, designs, prices or conditions of sale, as they apply to this product. The product represented by this datasheet is subject to U.S. Export Law as contained in ITAR or the EAR regulations.

Product Datasheet **Discontinued 6/12/2006**

Revision: June 2006

Measured Performance Characteristics (Typical Performance at 25°C)
 Vd = 5 V, Id = 426 mA

Freq GHz	S11 Mag	S11 Ang	S21 Mag	S21 Ang	S12 Mag	S12 Ang	S22 Mag	S22 Ang
10.0	0.70	-143.04	6.61	-111.34	0.01	-168.96	0.72	-161.43
11.0	0.72	-148.99	6.22	-137.78	0.01	147.49	0.71	-167.09
12.0	0.74	-153.27	5.60	-158.19	0.01	120.12	0.69	-170.83
13.0	0.76	-158.81	4.98	-175.17	0.01	104.53	0.67	-173.74
14.0	0.76	-162.67	4.69	169.81	0.01	83.13	0.66	-176.02
15.0	0.77	-168.21	4.21	153.62	0.01	62.66	0.62	-177.66
16.0	0.77	-174.71	3.57	144.02	0.00	43.19	0.60	-178.65
17.0	0.72	177.36	3.40	148.90	0.00	-87.99	0.61	-177.60
18.0	0.57	176.18	4.97	143.96	0.00	174.63	0.61	178.78
19.0	0.59	-173.49	5.91	117.39	0.01	169.96	0.58	177.64
20.0	0.64	-173.30	6.03	95.73	0.01	135.28	0.57	178.03
21.0	0.69	-177.85	5.99	76.31	0.01	127.99	0.56	176.90
22.0	0.70	175.88	6.01	59.19	0.01	140.50	0.55	177.28
23.0	0.66	170.85	5.93	42.93	0.01	134.53	0.56	176.53
24.0	0.67	169.03	6.41	29.17	0.01	120.25	0.58	176.06
25.0	0.69	162.63	7.28	10.15	0.01	103.25	0.62	172.80
26.0	0.67	153.26	8.15	-11.85	0.01	93.65	0.65	165.75
27.0	0.62	142.68	9.52	-36.00	0.01	113.53	0.66	156.38
28.0	0.56	130.31	10.84	-66.22	0.01	108.19	0.69	140.26
29.0	0.49	108.94	11.85	-99.75	0.01	122.60	0.68	111.18
30.0	0.36	79.59	12.98	-145.33	0.01	119.70	0.55	63.11
31.0	0.28	34.03	10.88	158.71	0.02	93.55	0.41	-1.79
32.0	0.38	-22.09	7.18	108.74	0.02	68.09	0.38	-57.58
33.0	0.59	-62.63	3.97	66.22	0.00	102.75	0.46	-83.43
34.0	0.76	-92.10	1.95	31.57	0.01	176.37	0.54	-99.61
35.0	0.84	-112.08	0.86	5.80	0.01	142.57	0.61	-112.94
36.0	0.87	-126.30	0.33	-10.54	0.02	137.29	0.67	-121.85
37.0	0.89	-136.15	0.09	-4.90	0.02	121.81	0.70	-128.85
38.0	0.90	-143.67	0.06	68.80	0.02	102.42	0.74	-135.77
39.0	0.91	-149.86	0.09	82.31	0.02	91.93	0.77	-140.69
40.0	0.91	-154.71	0.10	77.21	0.02	94.95	0.79	-146.54

Note: The data contained in this document is for information only. Northrop Grumman reserves the right to change without notice the specifications, designs, prices or conditions of sale, as they apply to this product. The product represented by this datasheet is subject to U.S. Export Law as contained in ITAR or the EAR regulations.



Product Datasheet **Discontinued 6/12/2006**

Revision: June 2006

Measured Performance Characteristics (Typical Performance at 25°C)
Vd = 5.0 V, Id = 426 mA

Pulsed Gain Versus Frequency

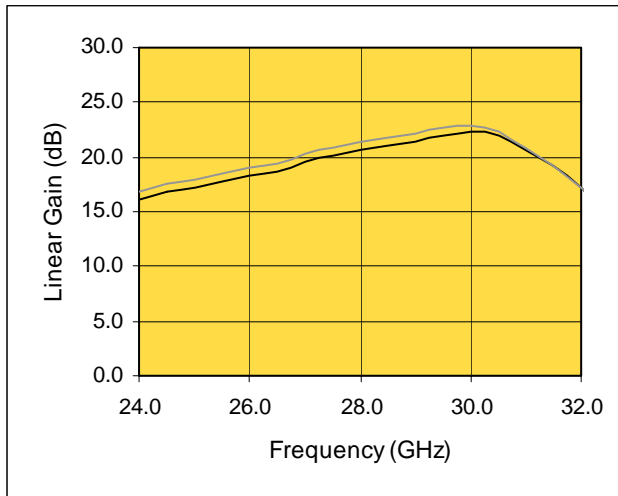

Fixtured P1dB Versus Frequency

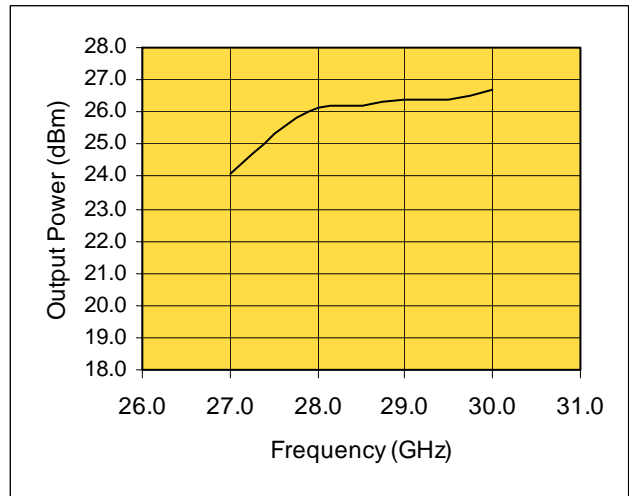

Input Return Loss Versus Frequency

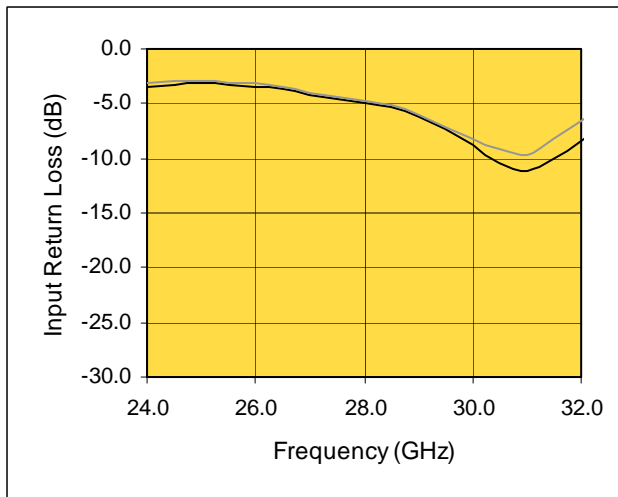

Output Return Loss Versus Frequency

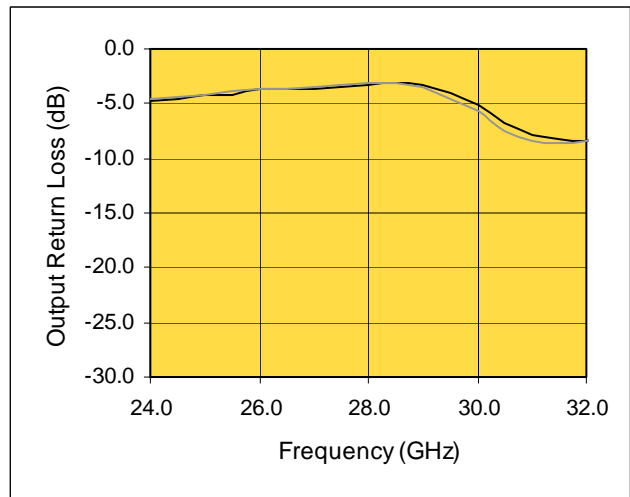

Note: The data contained in this document is for information only. Northrop Grumman reserves the right to change without notice the specifications, designs, prices or conditions of sale, as they apply to this product. The product represented by this datasheet is subject to U.S. Export Law as contained in ITAR or the EAR regulations.



Product Datasheet **Discontinued 6/12/2006**

Revision: June 2006

Die Size and Bond Pad Locations

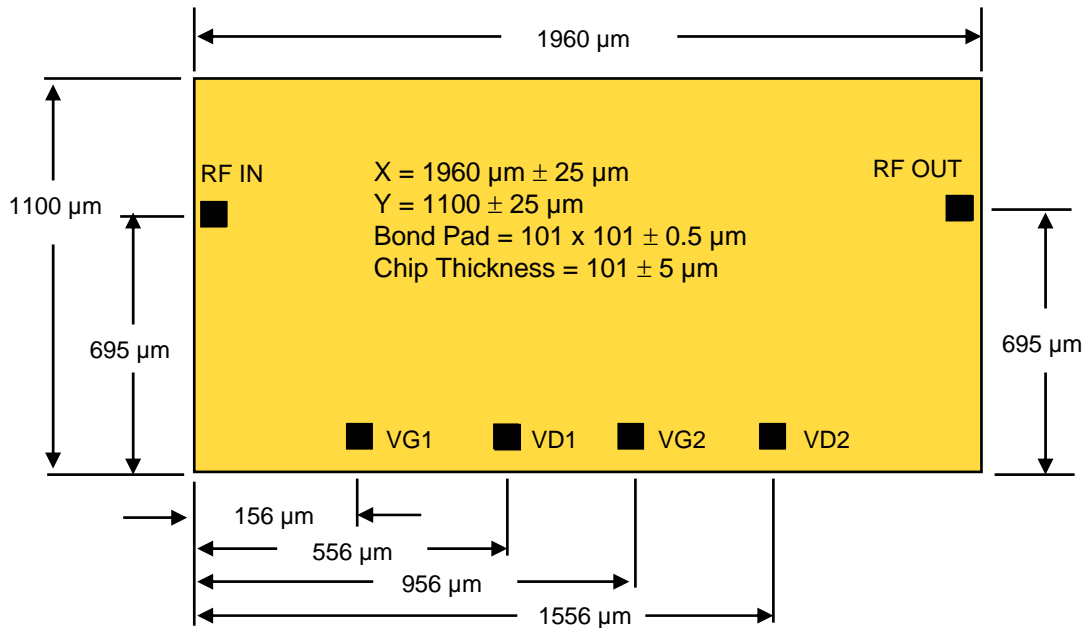

Suggested Bonding Arrangement

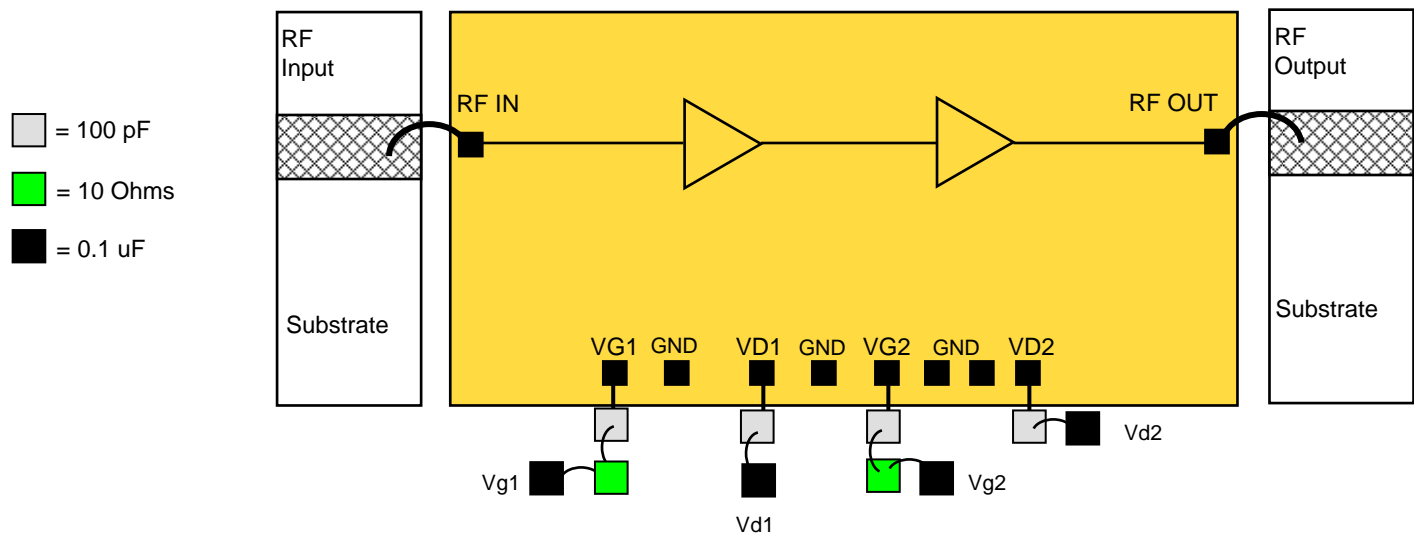

Recommended Assembly Notes

1. Bypass caps should be 100 pF ceramic (single-layer) placed no further than 30 mils from the amplifier.
2. Best performance obtained from use of <10 mil (long) by 3 by 0.5 mil ribbons on input and output.

Note: The data contained in this document is for information only. Northrop Grumman reserves the right to change without notice the specifications, designs, prices or conditions of sale, as they apply to this product. The product represented by this datasheet is subject to U.S. Export Law as contained in ITAR or the EAR regulations.