

X=3380µm Y=1260µm

Product Features

- ◆ RF Frequency: 40 to 44 GHz
- ◆ Linear Gain: 13 dB typ.
- ◆ P1 dB: 27 dBm typ.
- ◆ IP3: 36 dBm typ.
- ◆ Die Size: 4.3 sq. mm.
- ◆ DC Power: 5 VDC @ 1.08 A

Applications

- ◆ Point-to-Point Digital Radios
- ◆ Point-to-Multipoint Digital Radios

Product Description

The APH474 monolithic HEMT amplifier is a broadband, two-stage power device, designed for use in commercial digital radios and wireless LANs. To ensure rugged and reliable operation, HEMT devices are fully passivated. Both bond pad and backside metallization are Ti/Au, which is compatible with conventional die attach, thermocompression, and thermosonic wire bonding assembly techniques.

Performance Characteristics (Ta = 25°C)

Specification	Min	Typ	Max	Unit
Frequency	40		44	GHz
Linear Gain	11	13		dB
P1dB		27		dBm
IP3		36		dBm
Input Return Loss				dB
Output Return Loss				dB
Vd1, Vd2		5		V
Vg1, Vg2		-0.49		V
Id1		540		mA
Id2		540		mA

Absolute Maximum Ratings (Ta = 25°C)

Parameter	Min	Max	Unit
Vd1, Vd2		5.5	V
Id1		600	mA
Id2		600	mA
Vg1, Vg2	-1	+0.3	V
Input drive level		19	dBm
Assy. Temperature (60 seconds)		300	deg. C

Preliminary Information: The data contained in this document describes new products in the sampling or preproduction phase of development and is for information only. Northrop Grumman reserves the right to change without notice the characteristic data and other specifications as they apply to this product. The product represented by this datasheet is subject to U.S. Export Law as contained in ITAR or the EAR regulations.



Preliminary Datasheet **Discontinued 7/2005**

Revision: July 2005

Measured performance characteristics (Typical at 25C)
 Vd1= 5 V, Id= 540 mA; Vd2= 5V, Vd2= 540 mA

Freq GHz	S11 Mag	S11 Ang	S21 Mag	S21 Ang	S12 Mag	S12 Ang	S22 Mag	S22 Ang
38.00	0.61	-146.86	1.81	113.90	0.01	89.79	0.83	81.41
38.50	0.57	-154.61	2.40	94.20	0.01	74.90	0.84	74.16
39.00	0.51	-164.31	3.11	69.92	0.01	68.68	0.82	64.68
39.50	0.42	-174.98	3.88	40.91	0.02	47.20	0.76	52.92
40.00	0.31	176.90	4.33	10.08	0.02	29.02	0.65	42.22
40.50	0.20	171.61	4.48	-19.53	0.02	10.47	0.54	35.20
41.00	0.11	172.10	4.41	-46.35	0.02	-0.94	0.44	30.33
41.50	0.03	-167.10	4.25	-70.37	0.01	-18.70	0.37	31.09
42.00	0.05	-33.81	4.20	-92.76	0.01	-29.11	0.33	30.30
42.50	0.14	-29.79	4.18	-115.02	0.01	-60.02	0.31	25.00
43.00	0.24	-33.53	4.27	-139.17	0.01	-57.70	0.29	16.32
43.50	0.36	-39.67	4.25	-164.86	0.01	-99.40	0.27	3.22
44.00	0.48	-49.95	4.05	167.80	0.01	-110.53	0.23	-17.84
44.50	0.57	-61.13	3.62	142.44	0.00	155.69	0.19	-44.69
45.00	0.64	-71.40	3.15	116.89	0.00	173.56	0.16	-76.11
45.50	0.68	-81.27	2.64	94.82	0.01	95.32	0.16	-111.62
46.00	0.68	-91.31	2.18	73.06	0.01	94.56	0.17	-148.64

Preliminary Information: The data contained in this document describes new products in the sampling or preproduction phase of development and is for information only. Northrop Grumman reserves the right to change without notice the characteristic data and other specifications as they apply to this product. The product represented by this datasheet is subject to U.S. Export Law as contained in ITAR or the EAR regulations.



Preliminary Datasheet **Discontinued 7/2005**

Revision: July 2005

Measured performance characteristics (Typical at 25C)
Vd1= 5 V, Id= 540 mA; Vd2= 5V, Vd2= 540 mA

Fixtured Gain Versus Frequency

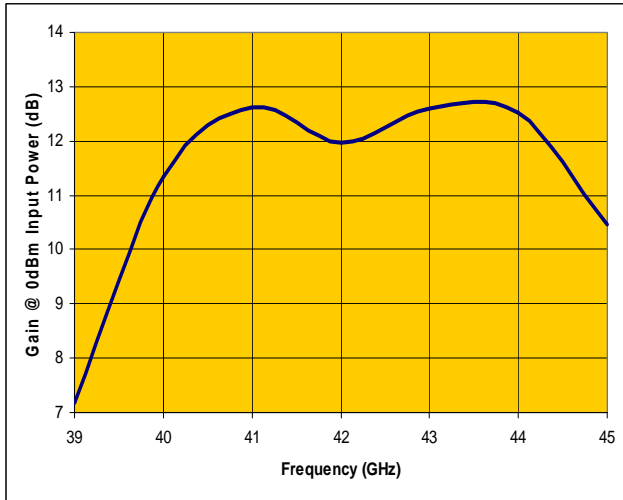

*Fixtured data

Power Versus Frequency

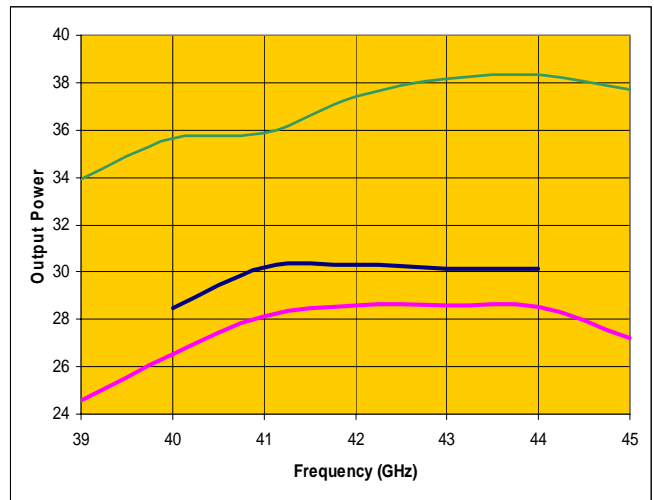

*Fixtured data

— OIP3 — P1dB — P3 dB

Input Return Loss Versus Frequency

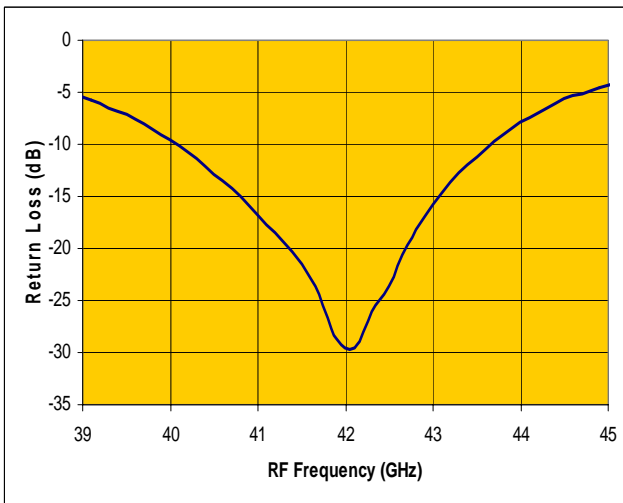

Output Return Loss Versus Frequency

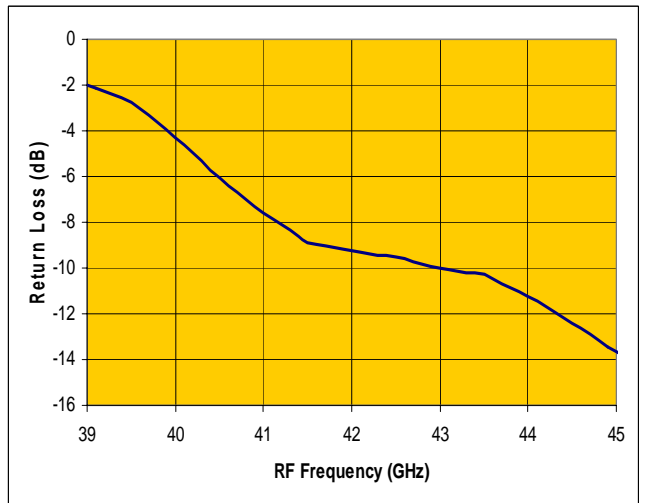

Preliminary Information: The data contained in this document describes new products in the sampling or preproduction phase of development and is for information only. Northrop Grumman reserves the right to change without notice the characteristic data and other specifications as they apply to this product. The product represented by this datasheet is subject to U.S. Export Law as contained in ITAR or the EAR regulations.



Preliminary Datasheet **Discontinued 7/2005**

Revision: July 2005

Die Size and Bond Pad Locations

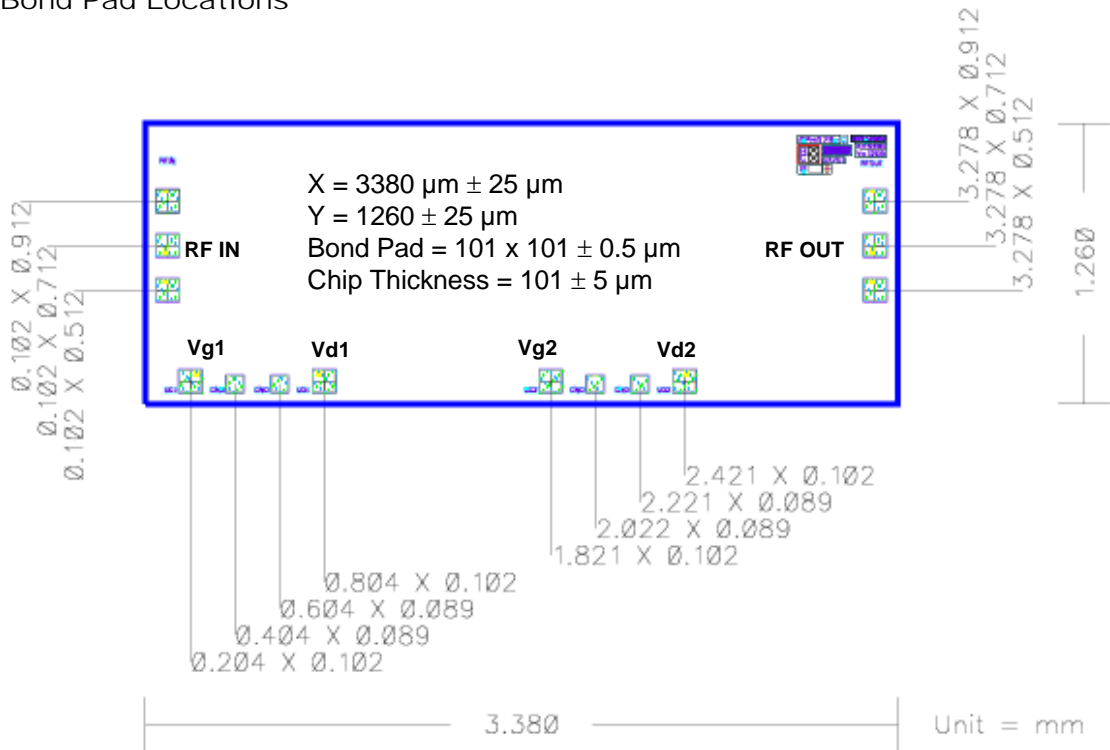

Suggested Bonding

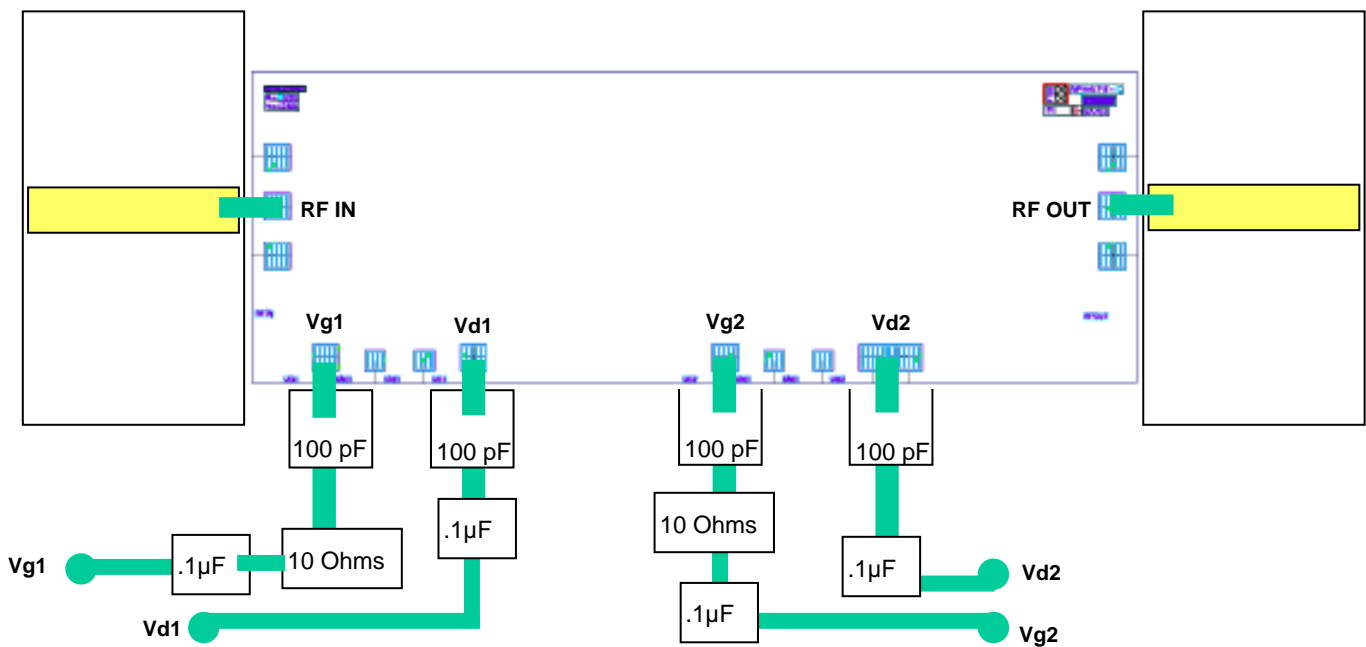

Preliminary Information: The data contained in this document describes new products in the sampling or preproduction phase of development and is for information only. Northrop Grumman reserves the right to change without notice the characteristic data and other specifications as they apply to this product. The product represented by this datasheet is subject to U.S. Export Law as contained in ITAR or the EAR regulations.