

X=2770µm Y=1790µm

Product Features

- ◆ RF frequency: 71 to 76 GHz
- ◆ Linear gain: > 7 dB
- ◆ P1dB: ~18 dBm
- ◆ Unconditionally stable
- ◆ DC Power: 4 Vdc at 240 mA
- ◆ Die Size: < 5.0 sq. mm

Performance Characteristics (Ta = 25°C)

Specification	Min	Typ	Max	Unit
Frequency	71		76	GHz
Linear Gain	7	8		dB
Input Return Loss	9	12		dB
Output Return Loss		3		dB
P1dB		18		dBm
Vd1 and Vd2		4		V
Vg		-0.2		V
Id1		80		
Id2		160		mA

Applications

- ◆ New FCC E-Band Communication Systems @ 71-76 GHz Frequency Band
- ◆ Short-Haul / High Capacity Links
- ◆ Enterprise Wireless LAN
- ◆ Wireless Fiber Replacement

Product Description

The APH582 monolithic HEMT is a broadband, two-stage, power amplifier. To ensure rugged and reliable operation, HEMT devices are fully passivated. Both bond pad and backside metallization are Ti/Au, which is compatible with conventional die attach, thermocompression and thermosonic wire bonding assembly techniques.

Absolute Maximum Ratings (Ta = 25°C)

Parameter	Min	Max	Unit
Vd1, Vd2		4.5	V
Id1		100	mA
Id2		200	mA
Vg1, Vg2	-0.8	0.3	V
Input drive level		12	dBm
Assy. Temperature (60 seconds)		300	deg. C

Preliminary Information: The data contained in this document describes new products in the sampling or preproduction phase of development and is for information only. Northrop Grumman reserves the right to change without notice the characteristic data and other specifications as they apply to this product. The product represented by this datasheet is subject to U.S. Export Law as contained in ITAR or the EAR regulations.



Preliminary Datasheet **Discontinued May 2007**

Revision: May 2007

Measured Performance Characteristics (Typical Performance at 25°C)
 $V_{d1} = V_{d2} = 4V$ and $I_{d1} = 80mA$ and $I_{d2} = 160mA$

Linear Gain Versus Frequency

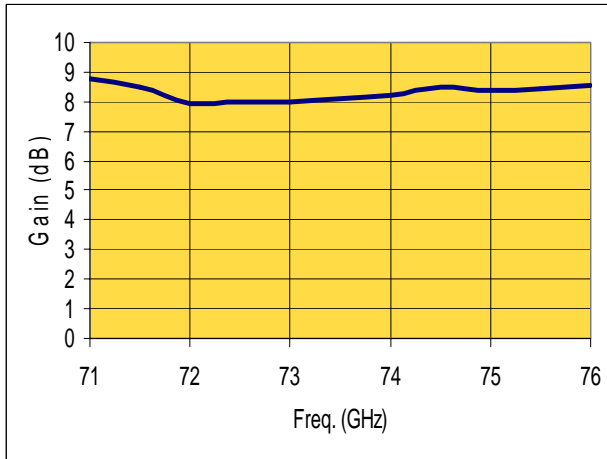

Input Return Loss Versus Frequency

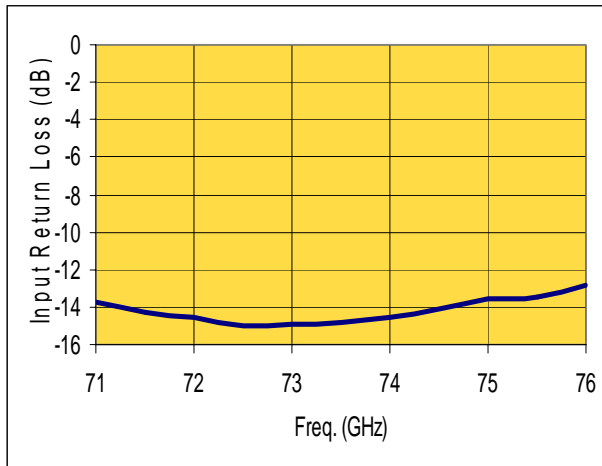

Output Return Loss Versus Frequency

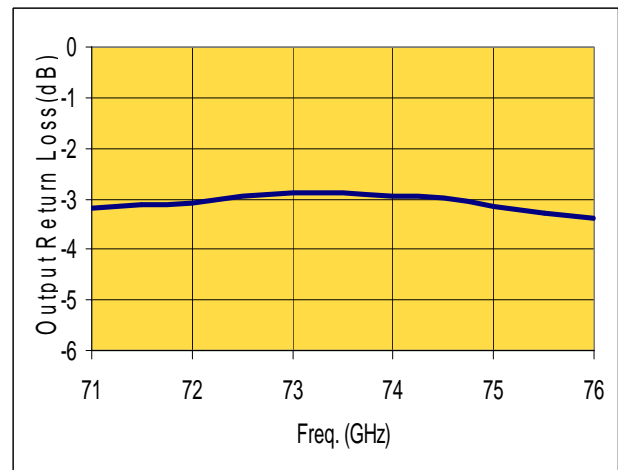

Preliminary Information: The data contained in this document describes new products in the sampling or preproduction phase of development and is for information only. Northrop Grumman reserves the right to change without notice the characteristic data and other specifications as they apply to this product. The product represented by this datasheet is subject to U.S. Export Law as contained in ITAR or the EAR regulations.

Preliminary Datasheet **Discontinued May 2007**

Revision: May 2007

Die Size and Bond Pad Locations

X Dimension: 2.77 ± 0.025 mm
 Y Dimension: 1.79 ± 0.025 mm
 RF Bond Pad Dimension: 0.05×0.05 mm

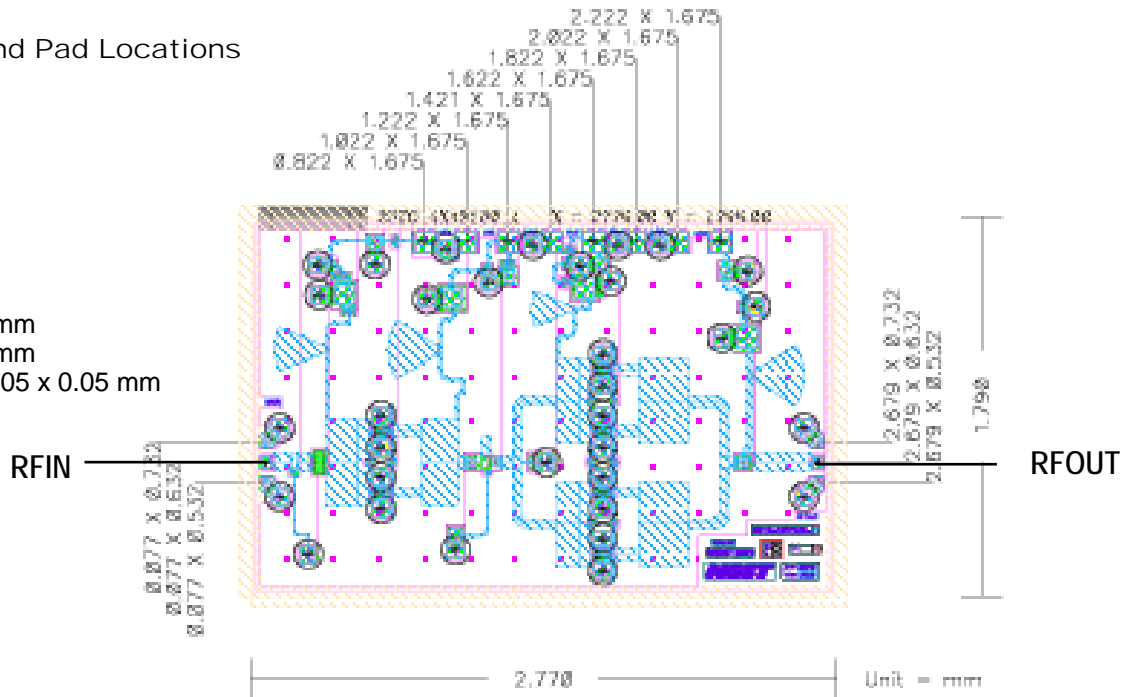

Suggested Bonding Arrangement

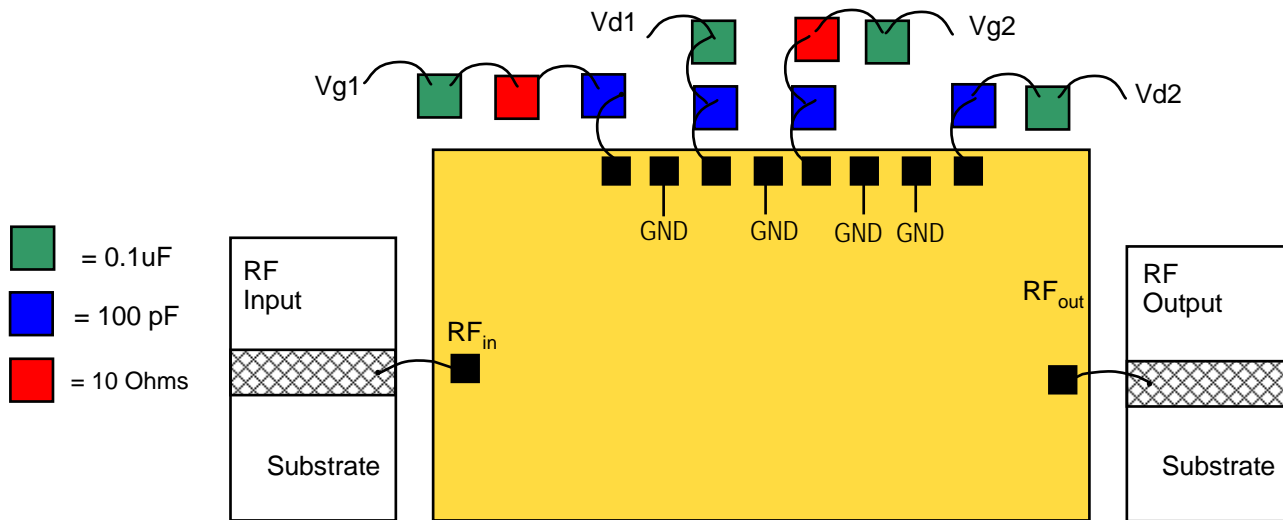

Recommended Assembly Notes

1. Bypass caps should be 100 pF (approximately) ceramic (single-layer) placed no farther than 30 mils from the amplifier.
2. Best performance obtained from use of <10 mil (long) by 3 by 0.5 mil ribbons on input and output.

Preliminary Information: The data contained in this document describes new products in the sampling or preproduction phase of development and is for information only. Northrop Grumman reserves the right to change without notice the characteristic data and other specifications as they apply to this product. The product represented by this datasheet is subject to U.S. Export Law as contained in ITAR or the EAR regulations.