

X=3250 μm Y=1500 μm

**Product Features**

- ◆ RF Frequency: 92 to 96 GHz
- ◆ Linear Gain: 17 dB typ.
- ◆ Noise Figure: 5 dB typ.
- ◆ Die Size: 4.9 sq. mm.
- ◆ DC Power: 2 VDC @ 34 mA

**Applications**

- ◆ Short Haul / High Capacity Links
- ◆ Sensors
- ◆ Millimeter-wave Imaging

**Description and Application**

The ALH394 is a broadband, three-stage, low noise monolithic HEMT amplifier designed for use in commercial digital microwave radios and wireless LANs. The small die size allows for extremely compact packaging. To ensure rugged and reliable operation, HEMT devices are fully passivated. Both bond pad and backside metallization are Ti/Au, which is compatible with conventional die attach, thermocompression and thermosonic wire bonding assembly techniques.

**Performance Characteristics (Ta = 25°C)**

Specification	Min	Typ	Max	Unit
Frequency	92		96	GHz
Linear Gain		17		dB
Noise Figure		5		dB
Input Return Loss	2			dB
Output Return Loss	7			dB
P1dB		5		dBm
Vd1, Vd2, Vd3		2		V
Vg1, Vg2		-0.4		V
Vg3		-0.2		V
Id1		7		mA
Id2		7		mA
Id3		20		mA

**Absolute Maximum Ratings (Ta = 25°C)**

Parameter	Min	Max	Unit
Vd1, Vd2, Vd3		3	V
Id1		10	mA
Id2		10	mA
Id3		25	mA
Vg1, Vg2, Vg3	-0.8	0.2	V
Input drive level		-5	dBm
Assy. Temperature (60 seconds)		300	deg. C

Note: The data contained in this document is for information only. Northrop Grumman reserves the right to change without notice the specifications, designs, prices or conditions of sale, as they apply to this product. The product represented by this datasheet is subject to U.S. Export Law as contained in the ITAR. **Export of the product represented by this datasheet will require a U.S. Department of State export license.**



Product Datasheet

Revision: November 2007

Measured Performance Characteristics (Typical Performance at 25°C)  
 $V_{d1} = V_{d2} = V_{d3} = 2V$ ,  $I_{d1} = 7\text{ mA}$ ,  $I_{d2} = 7\text{ mA}$ ,  $I_{d3} = 20\text{ mA}$

Linear Gain Versus Frequency

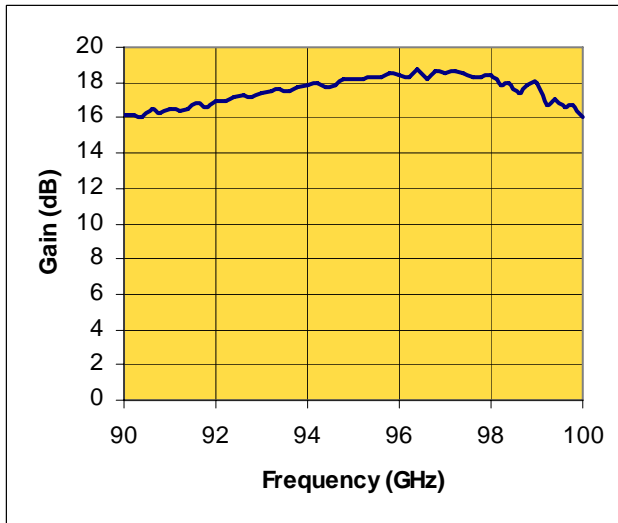

Noise Figure Versus Frequency

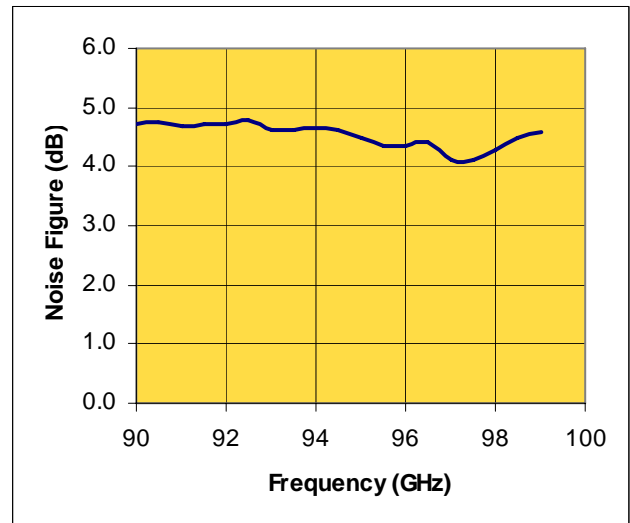

Input Return Loss Versus Frequency

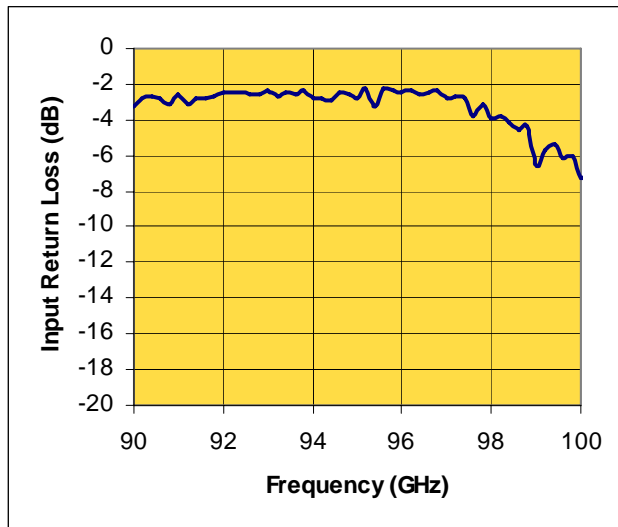

Output Return Loss Versus Frequency

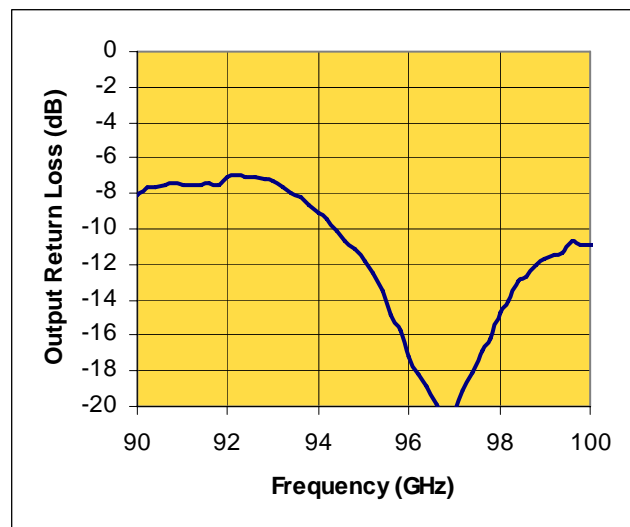

Note: The data contained in this document is for information only. Northrop Grumman reserves the right to change without notice the specifications, designs, prices or conditions of sale, as they apply to this product. The product represented by this datasheet is subject to U.S. Export Law as contained in the ITAR. **Export of the product represented by this datasheet will require a U.S. Department of State export license.**



Product Datasheet

Revision: November 2007

Measured Performance Characteristics (Typical Performance at 25°C)  
 $V_{d1} = V_{d2} = V_{d3} = 2V$ ,  $I_{d1} = 7 \text{ mA}$ ,  $I_{d2} = 7 \text{ mA}$ ,  $I_{d3} = 20 \text{ mA}$

Wide-Band Linear Gain Versus Frequency

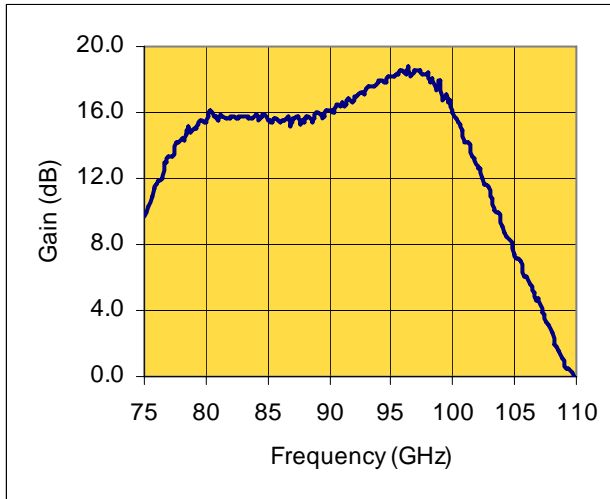

Wide-Band Return Loss Versus Frequency

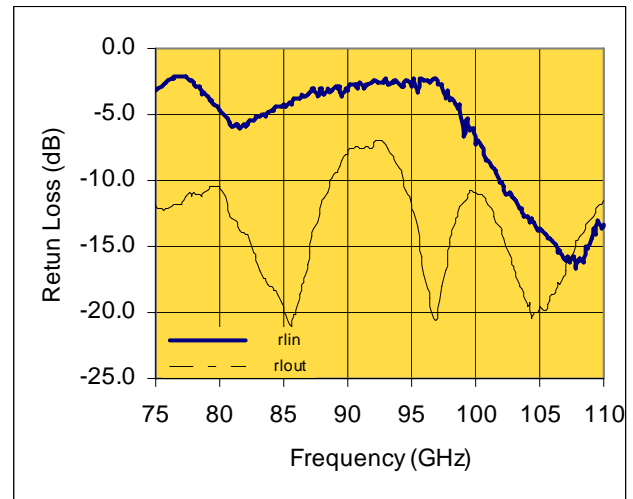

Note: The data contained in this document is for information only. Northrop Grumman reserves the right to change without notice the specifications, designs, prices or conditions of sale, as they apply to this product. The product represented by this datasheet is subject to U.S. Export Law as contained in the ITAR. **Export of the product represented by this datasheet will require a U.S. Department of State export license.**



## Product Datasheet

Revision: November 2007

Measured Performance Characteristics (Typical Performance at 25°C)

Vd1 = Vd2 = Vd3 = 2V, Id1 = 7 mA, Id2 = 7 mA, Id3 = 20 mA

Freq GHz	S11 Mag	S11 Ang	S21 Mag	S21 Ang	S12 Mag	S12 Ang	S22 Mag	S22 Ang
75.0	0.70	99.9	3.04	-17.6	0.00	-118.4	0.26	-165.8
76.0	0.76	91.7	3.81	-42.4	0.00	-132.1	0.25	162.3
77.0	0.78	80.6	4.63	-72.5	0.00	-121.1	0.26	131.0
78.0	0.74	70.4	5.27	-102.7	0.00	141.4	0.28	102.9
79.0	0.65	62.9	5.63	-133.7	0.00	-171.5	0.29	84.1
80.0	0.58	61.7	5.91	-161.8	0.00	134.8	0.30	59.5
81.0	0.51	64.7	5.98	167.5	0.00	6.0	0.23	44.0
82.0	0.51	68.6	6.09	141.8	0.00	9.3	0.20	36.3
83.0	0.55	68.8	6.17	118.2	0.00	-81.1	0.15	30.4
84.0	0.58	67.5	6.25	94.3	0.01	-57.3	0.13	39.6
85.0	0.61	64.1	5.93	70.7	0.01	-151.4	0.10	38.7
86.0	0.65	62.4	5.87	48.8	0.00	-135.8	0.10	76.9
87.0	0.68	56.4	6.00	23.0	0.01	-154.5	0.17	89.4
88.0	0.70	51.4	5.90	3.0	0.01	172.8	0.26	81.9
89.0	0.72	45.1	6.27	-18.3	0.01	178.4	0.34	66.2
90.0	0.69	40.7	6.41	-40.5	0.01	169.1	0.40	50.6
91.0	0.75	32.6	6.72	-63.3	0.02	136.7	0.42	32.9
92.0	0.75	26.2	7.07	-86.0	0.01	114.8	0.44	17.5
93.0	0.76	17.8	7.45	-111.4	0.01	83.1	0.43	-4.5
94.0	0.73	8.7	7.79	-136.7	0.01	69.3	0.35	-28.8
95.0	0.72	0.1	8.07	-162.6	0.01	41.2	0.26	-54.6
96.0	0.75	-12.6	8.33	168.9	0.01	39.4	0.14	-95.3
97.0	0.73	-28.9	8.48	136.1	0.01	25.7	0.10	-179.8
98.0	0.64	-46.6	8.36	104.7	0.01	-6.8	0.18	111.5
99.0	0.47	-60.6	7.89	73.3	0.02	-53.8	0.26	74.2
100.0	0.43	-80.6	6.34	41.2	0.01	-88.6	0.29	46.0
101.0	0.38	-92.4	5.14	11.0	0.01	-96.4	0.26	26.0
102.0	0.31	-102.7	4.30	-15.7	0.01	-149.7	0.20	13.9
103.0	0.27	-111.8	3.58	-39.9	0.01	-179.2	0.15	12.1
104.0	0.23	-123.6	2.86	-61.8	0.01	132.9	0.11	20.7
105.0	0.21	-127.7	2.33	-83.5	0.00	-163.4	0.11	46.1

Note: The data contained in this document is for information only. Northrop Grumman reserves the right to change without notice the specifications, designs, prices or conditions of sale, as they apply to this product. The product represented by this datasheet is subject to U.S. Export Law as contained in the ITAR. **Export of the product represented by this datasheet will require a U.S. Department of State export license.**



Die Size and Bond Pad Locations

X = 3250  $\mu\text{m}$   $\pm$  25  $\mu\text{m}$   
 Y = 1500  $\pm$  25  $\mu\text{m}$   
 RF Bond Pad = 50 x 50  $\pm$  0.5  $\mu\text{m}$   
 DC Bond Pad = 101 x 101  $\pm$  0.5  $\mu\text{m}$   
 Chip Thickness = 101  $\pm$  5  $\mu\text{m}$

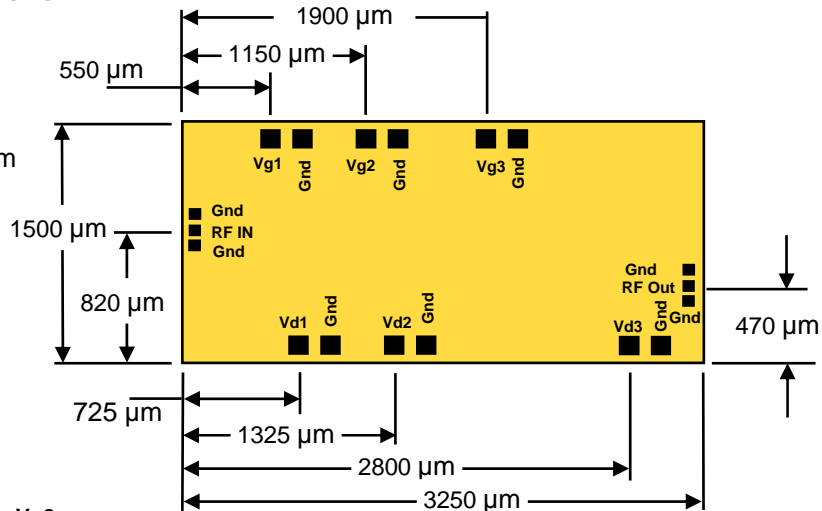

Suggested Bonding

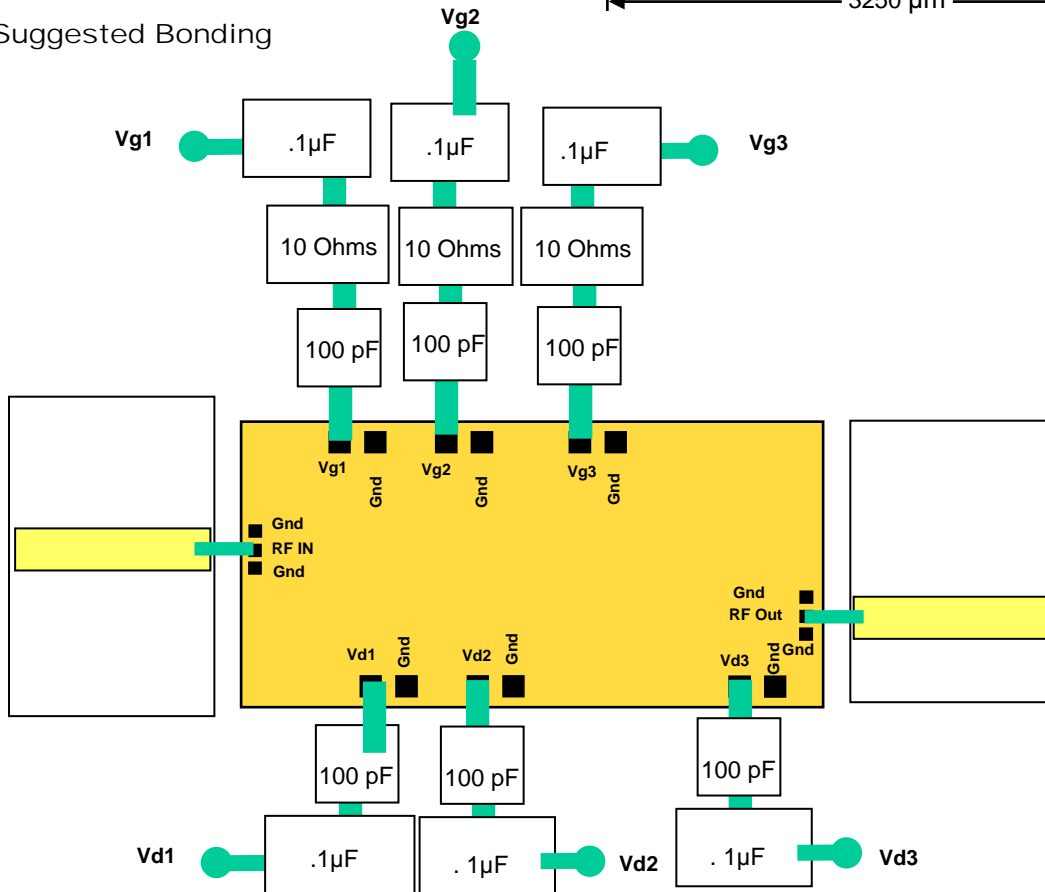

Recommended Assembly Notes

1. Bypass caps should be 100 pF (approximately) ceramic (single-layer) placed no farther than 30 mils from the amplifier.
2. Best performance obtained from use of <10 mil (long) by 3 by 0.5 mil ribbons on input and output.

Note: The data contained in this document is for information only. Northrop Grumman reserves the right to change without notice the specifications, designs, prices or conditions of sale, as they apply to this product. The product represented by this datasheet is subject to U.S. Export Law as contained in the ITAR. **Export of the product represented by this datasheet will require a U.S. Department of State export license.**