

X=3100 μm Y=1200 μm

Applications

- ◆ Short Haul / High Capacity Links
- ◆ Sensors

Features

- ◆ X2 Active Multiplier
- ◆ Input frequency: 46 to 48 GHz
- ◆ Output frequency: 92 to 96 GHz
- ◆ Conversion Gain: 5 dB (typ.)
- ◆ Die Size: 3.7 sq. mm.
- ◆ RF Input Power: -5 dB (typ.)
- ◆ Die Size: < 3.8 sq. mm

Product Description

The XDH150 is a monolithic HEMT multiplier designed for use in commercial digital radios and wireless LANs. To ensure rugged and reliable operation, HEMT devices are fully passivated. Both bond pad and backside metallization are Ti/Au, which is compatible with conventional die attach, thermocompression, and thermosonic wire bonding assembly techniques.

Performance Characteristics (T<sub>OP</sub> = 25°C)

Specification	Min	Typ	Max	Unit
Input Frequency	46		48	GHz
Output Frequency	92		96	GHz
Input Power		-5		dBm
Output Power	-1	0		dBm
Vd1		4		V
Id1		70		mA
Vd2		4		V
Id2		0.3		mA
Vg1		0		V
Vg2		-0.8		V

Absolute Maximum Ratings (T<sub>OP</sub> = 25°C)

Parameter	Min	Max	Unit
Vd1		5.5	V
Id1		90	mA
Vd2		5.5	V
Id2		20	mA
Vg1	-1	+0.3	V
Vg2	-1	+0.3	V
Input Drive Level		0	dBm
Assy. Temperature (60 seconds)		300	°C

**Preliminary Information:** The data contained in this document describes new products in the sampling or preproduction phase of development and is for information only. Northrop Grumman reserves the right to change without notice the characteristic data and other specifications as they apply to this product. The product represented by this datasheet is subject to U.S. Export Law as contained in the ITAR. **Export of the product represented by this datasheet will require a U.S. Department of State export license.**



Measured Performance Characteristics ( $T_{OP} = 25^{\circ}C$ )  
Pin = -5 dBm

Conversion Gain

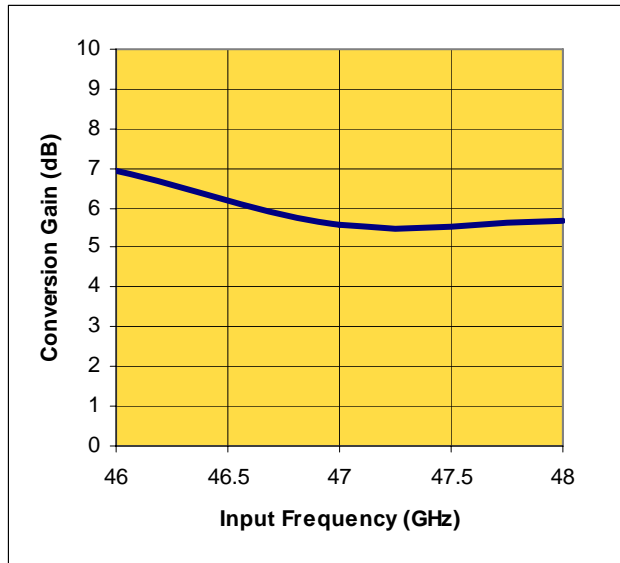

Output Power

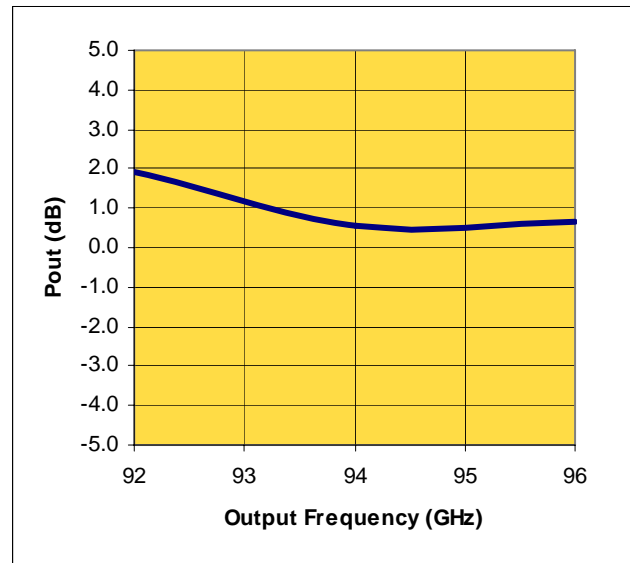

**Preliminary Information:** The data contained in this document describes new products in the sampling or preproduction phase of development and is for information only. Northrop Grumman reserves the right to change without notice the characteristic data and other specifications as they apply to this product. The product represented by this datasheet is subject to U.S. Export Law as contained in the ITAR. **Export of the product represented by this datasheet will require a U.S. Department of State export license.**



Die Size and Bond Pad Locations

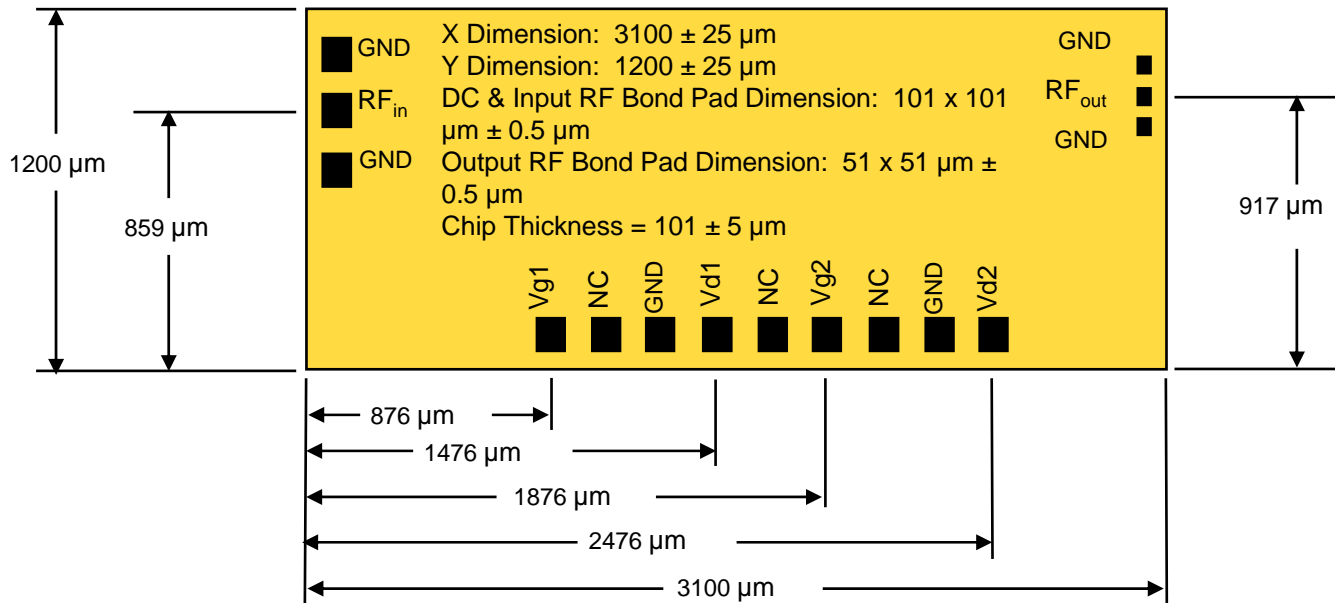

Application Circuit

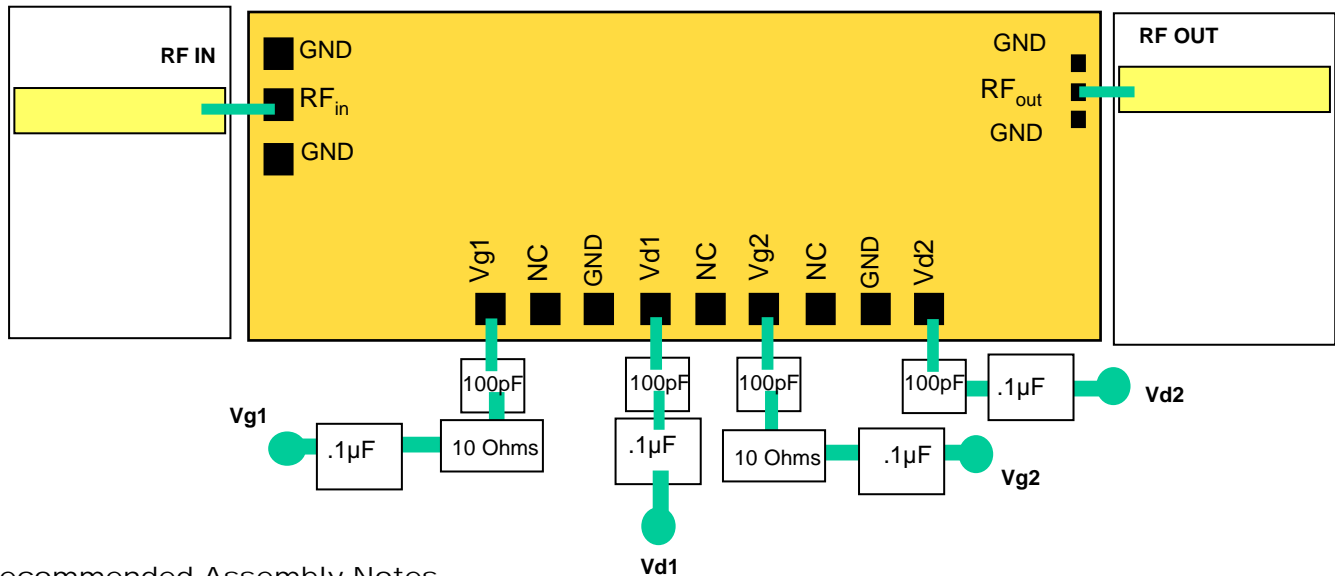

Recommended Assembly Notes

1. Bypass caps should be 100 pF (approximately) ceramic (single-layer) placed no farther than 30 mils from the amplifier.
2. Input bond pad & dc bias pads dimensions are 0.1mm x 0.1mm (4mil x 4mil).
3. Output bond pad dimension is 0.05mm x 0.05mm (2mil x 2mil).
4. Best performance obtained from use of <10 mil (long) by 3 by 0.5 mil ribbon on input bond pads and <6 mil (long) by 1.5 by 0.5 mil ribbon on output bond pads

**Preliminary Information:** The data contained in this document describes new products in the sampling or preproduction phase of development and is for information only. Northrop Grumman reserves the right to change without notice the characteristic data and other specifications as they apply to this product. The product represented by this datasheet is subject to U.S. Export Law as contained in the ITAR. **Export of the product represented by this datasheet will require a U.S. Department of State export license.**